

Side 1 View

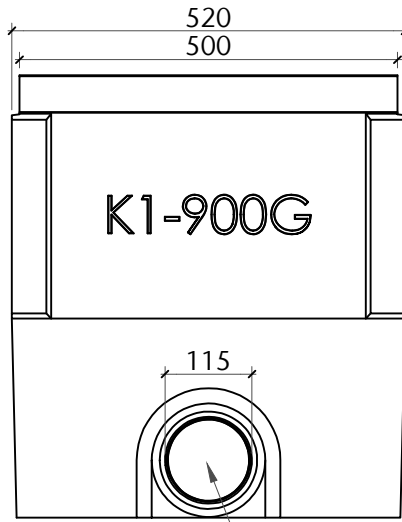

Front View

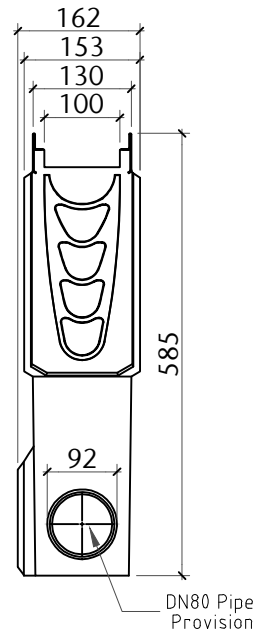

Side 2 View

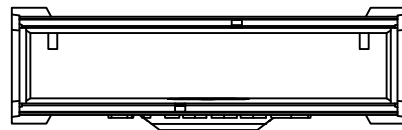

Top View

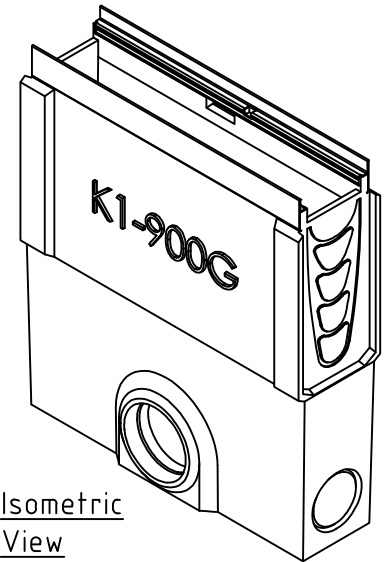

Isometric View

Description	Part Number
ACO KlassikDrain K1-900G Slim-line Pit - (0.5m) w/ Galvanised Edge Rail	142838
ACO KlassikDrain KS1-900S Slim-line Pit - (0.5m) w/ Stainless Steel Edge Rail	142839

**Materials**

K100 channels shall be manufactured from polyester resin polymer concrete with integrally cast-in galvanised steel edge rails. Properties of polymer concrete will be as follows with supporting documentation:

Compressive Strength:	98 MPa	Water Vapour Transmission:	0.0364g/m <sup>2</sup>
Flexural Strength:	26 MPa	Non Flammable:	Yes
Tensile Strength:	14 MPa	Roughness (Mannings):	n=0.011
Water Absorption:	0.07%	Resistant to Weathering:	Yes
Frost Proof:	Yes	Dilute Acid and Alkali Resistant:	Yes
Coefficient of Expansion/ Contraction:	2.02x10 <sup>-5</sup> /°C		

**Grates**

Insert specification for the selected grate. Refer to the relevant ACO Specification Information sheet, click: <http://www.acodrain.com.au/resources>

**Installation**

The complete drainage system shall be by ACO and to be installed for its intended purpose. Any deviation or partial use of the specified system and/or improper installation will void all warranties provided by ACO.

ACO Specification Information

Drawn: Danilo V.	Revision: 00
Verified: -	Date: Dec/21

Brand:	ACO KlassikDrain®
Product:	ACO KlassikDrain K1-900G / KS1-900S
Installation Type:	-



ACO Limited  
 Unit F/6 Percival Gull Place  
 Mangere  
 Auckland 2022  
 Tel: 0800 448 080  
 Fax: +64 9255 5114  
 Email: [info@aconz.co.nz](mailto:info@aconz.co.nz)