



Specifications

General

The surface drainage system shall be ACO's Brickslot with K100/KS100/H100K/H100KS* polymer concrete channel system with galvanised/ stainless* steel edge rails as manufactured by ACO.

Materials

K100/KS100/H100K/H100KS* channels shall be manufactured from polyester resin polymer concrete with integrally cast-in galvanised/ stainless* steel edge rails. Properties of polymer concrete will be as follows with supporting documentation:

Compressive Strength:	98 MPa
Flexural Strength:	26 MPa
Tensile Strength:	14 MPa

Water Absorption:	0.07%
Frost Proof:	YES
Coefficient of Expansion/ Contraction:	2.02x10-5/°C
Water Vapour Transmission:	0.0364g/m2
Non Flammable:	YES
Roughness (Mannings):	n=0.011
Resistant to Weathering:	YES
Dilute Acid and Alkali Resistant:	YES
SF Sealant Groove:	YES

Channels

K100/KS100/H100K/H100KS* channel shall be 100mm nominal internal width with an overall width of 130mm. All channels shall be interlocking with a male/female joint.

Brickslot

The Brickslot shall be manufactured from galvanised/stainless* steel and have minimum

properties and characteristics as follows:

- 10mm wide slot to blend in with paving joints
- Meets AS 1428.2 (Clause 9c); AS 3996 (Clause 3.3.5 & 3.3.6)
- 69mm slot height for maximum paver depth of 63mm
- Connector clip used to align Brickslot joint
- Intake area of 10,000mm² per metre of Brickslot/5,000mm² per half metre of Brickslot
- Access units to allow access for maintenance to be located at both ends of the drain, at the outlet and/or spaced at 20-30 metre intervals

Installation

The complete drainage system shall be by ACO and to be installed for its intended purpose. Any deviation or partial use of the specified system and/or improper installation will void all warranties provided by ACO.

*delete as appropriate

ACO DRAIN

Galvanized Brickslot 100

One meter unit

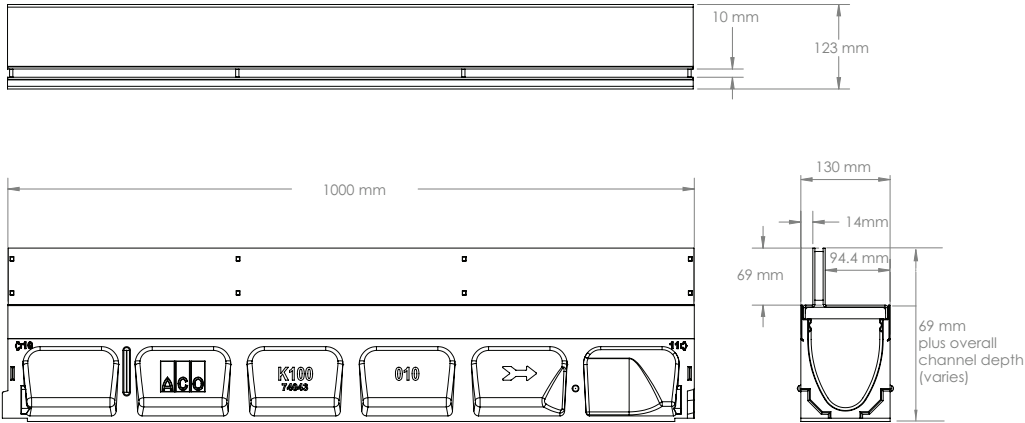

Half meter unit

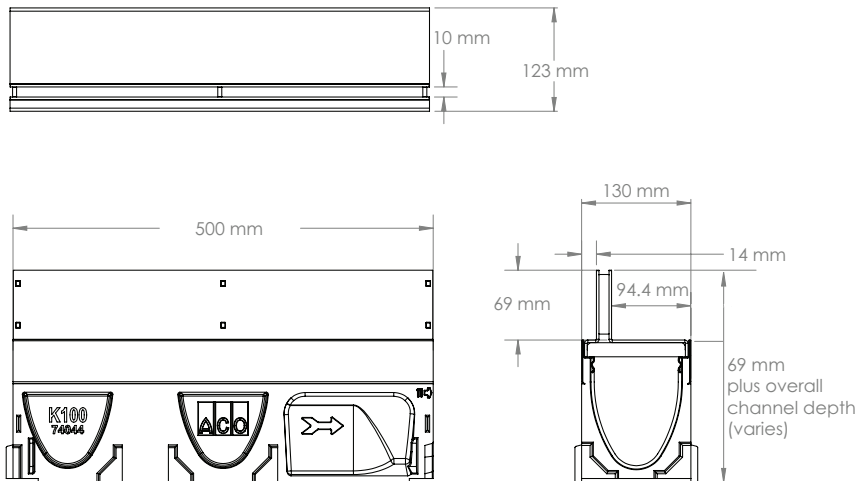

Description	Part No.	Invert mm	Weight kg
Brickslot 100 - (1m) Galvanized Steel	142464	Channel invert +69	7.8
Brickslot 100 - (0.5m) Galvanized Steel	142465	Channel invert +69	3.9
Brickslot 100 - (0.5m) Galvanized Steel Access Unit	142466	Channel invert +69	7.4

Notes:

1. For use with K100 and KS100 channels, and Series 900 catch basins.
2. Brickslot can also be used with SlabDrain H and HK channels.

ACO Specification Information

ACO Limited
Office & Warehouse
 Unit F/6 Percival Gull Place
 Mangere, Auckland 2022
 Tel: +64 9 815 9500
 Toll free: 0800 448 080
 Fax: +64 9 255 5114



Follow us on
Electronic Contact:
 info@aconz.co.nz
 www.aconz.co.nz



© September 2020 ACO Limited. All reasonable care has been taken in compiling the information in this document. All recommendations and suggestions on the use of ACO products are made without guarantee since the conditions of use are beyond the control of the company. It is the customer's responsibility to ensure that each product is fit for its intended purpose and that the actual conditions are suitable. ACO Limited, pursues a policy of continuous product development and reserves the right to amend specifications without notice